

SOLAR CHARGER CONTROLLER

REMOTE METER MT50

MT50 is an optional remote meter to monitor and program EP solar controller.

Compatible with:

LS-B, LS-BP, VS-BN, Tracer-BN, Tracer-A, eTracer, iTracer



Features:

- Automatic identify the controller, and display relevant parameter data
- Large-screen informative LCD displays all the operating data and system working status
- Simple and convenient operation
- Real-time alarm of failure information
- Longer communication distance based on RS485
- Diversified load control modes : Manual Control, Light ON/OFF, Light ON + Timer, Time Control
- Battery type selection : Gel, sealed, flooded and User (programmable)
- Programmable parameters
- Energy statistic display function

Surfacing mounting



Flush mounting



SOLAR CHARGER CONTROLLER

REMOTE METER MT50

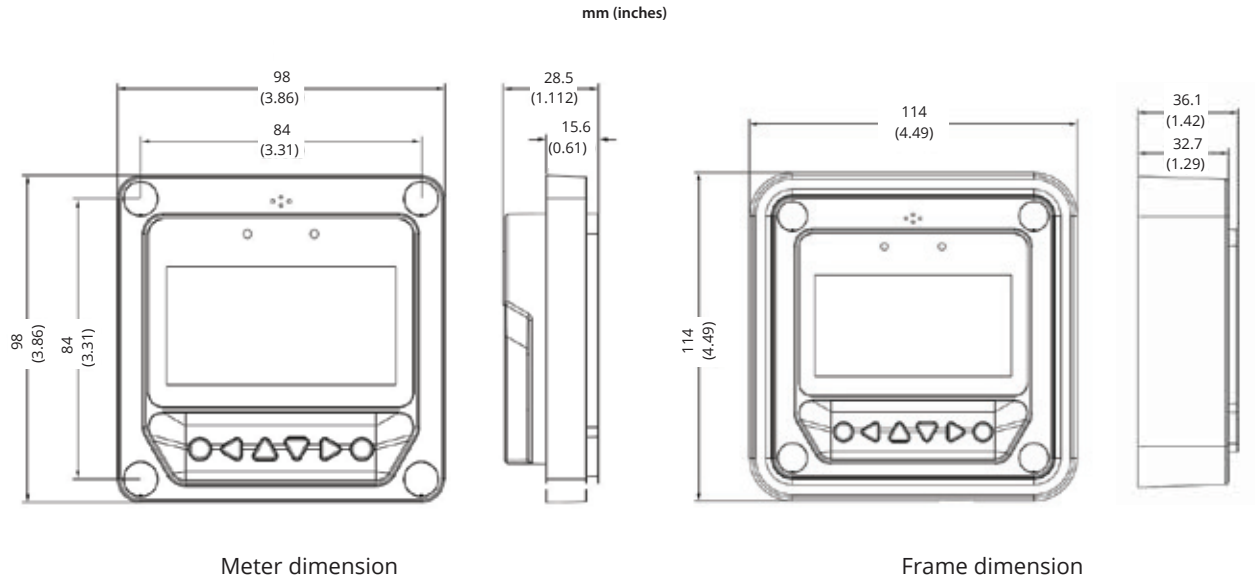

TECHNICAL SPECIFICATION

ELECTRICAL PARAMETER

| | |
|------------------|--|
| Self-consumption | Backlight and accoustic alarm on <65mA |
| | Backlight on <23mA |
| | Backlight off <15mA |

MECHANICAL PARAMETER

| | |
|----------------------|---------------------------|
| Faceplate dimensions | 98x98 mm / 3.86x3.86 in |
| Frame dimensions | 114x114 mm / 4.49x4.49 in |
| Connector type | RJ45 |
| Meter cable | 2m |
| Net weight | 0.190 Kg |

MECHANICAL PARAMETER

| | |
|---------------------------------|--------------------------|
| Working environment temperature | -20°C~+70°C / -4°F~158°F |
|---------------------------------|--------------------------|